

StationPro II Network Manual

rev. 06/27/2010

The StationPro system is designed so that two or three of the SP- II units can be networked together, allowing a total of nine radios and nine amplifiers to be independently controlled. The operation is completely transparent to the operator: selecting any transceiver or amplifier on any of the three SP-II controllers transfers the antenna and all control functions to the selected transceiver/amplifier pair, while taking the other radios off-line and grounding their antenna inputs.



In order to implement the networking feature, a small remote-controlled “Station Select Relay Unit” (SSRU) is required to transfer the antenna (or antenna switch) to the active SP-II controller. This relay unit is activated by the SP-II controllers, using an ordinary 6-conductor telephone-type cable, terminated with RJ-25 “telecom” connectors. Such cables are available from Radio Shack or any electronics distributor.

I. Installation and Hookup:

Installing Station Select Relay Unit: The SSRU has four SO-239 coax jacks and one RJ-25 control jack. As shown in the drawing below, the station antenna (or cable from an antenna switch) connects to the output coax jack, and coax jumpers connect from the STN1, STN2, and STN3 input coax jacks to the RF output jacks on each of the SP-II’s RF relay units (designated RLY1, RLY2 and RLY3 in the drawing).

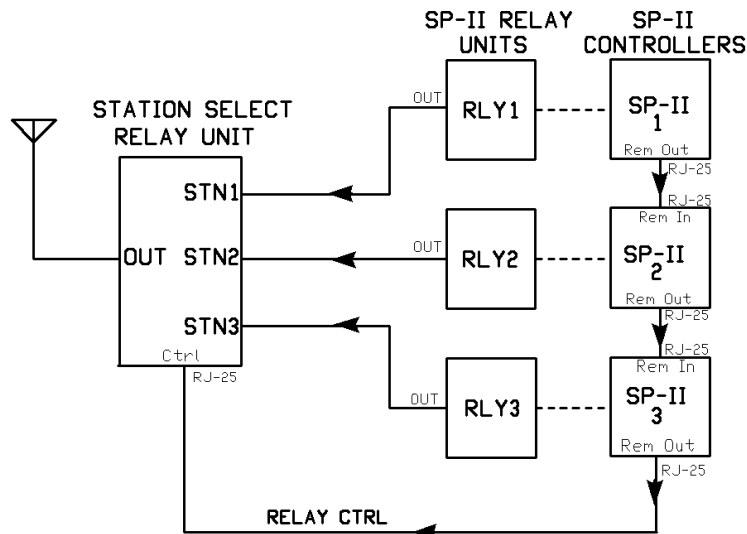

On the rear panel of each SP-II controller are two RJ-25 jacks, designated “Rem In” and “Rem Out.” These jacks are used to enable the three SP-II controllers to communicate with each other. As shown in the drawing, these ports are “daisy-chained” together, again using 6-conductor telephone-type cables, terminated with RJ-25 telecom connectors. One cable connects the “Rem Out” port on the first SP-II to the “Rem In” port on the second SP-II. A second cable connects the “Rem Out” port on the second SP-II to the “Rem In” port on the third SP-II. And finally, a third cable, connects the “Rem Out” port on the third SP-II to the Ctrl port on the SSRU. The drawing shows three SP-IIIs networked together, but the procedure is exactly the same if only two SP-IIIs are to be networked. In this case, the STN3 coax jack on the SSRU will not be used.

Setting the SP-II Addresses:

In order to implement the networking feature, each SP-II must be assigned a unique address. This address is selected by soldering a short jumper wire between pads on the microcontroller printed circuit board in each SP-II control unit. Installing this jumper only requires removing the top cover of the control unit. It is not necessary to remove the microcontroller board from the unit.



The photograph shows a jumper between pads labeled REMOUT and RLY1. This jumper assigns address STN1 to this particular SP-II controller. A jumper to RLY2 or RLY3 assigns addresses STN2 and STN3 respectively. *It is important that no two units be assigned the same address!*

II Operating Hints and Precautions:

As mentioned above, operation of networked SP-IIIs is fully automatic. In operation, only the selected SP-II will be active and “Off Line” will be displayed on the LCDs of the other SP-IIIs. If the operator depresses any transceiver or amplifier switch on an off-line SP-II, then that SP-II will become active and the previously active SP-II will go off-line. However, the first switch depression only brings the SP-II on-line and does not actually select a transceiver or amplifier. A second switch depression selects the chosen transceiver or amplifier

When networking SP-IIIs, there is only one operating precaution that must be observed. *All networked SP-IIIs must be turned on, before any SP-II can be used.* Otherwise, the Station Select Relay Unit will not operate, effectively grounding the antenna inputs on all rigs. Thus, before going on the air each day, one should verify that all SP-IIIs are powered

up and that the LCDs of non-selected SP-IIs indicate an off-line status. As a precaution against forgetting to turn them on, it is a good idea to leave all networked SP-IIs powered up continuously 24/7. Since each SP-II draws only four watts, the power consumption is negligible.

III. Circuit Description and Principles of Operation

Station Select Relay Unit:

As shown below, the SSRU consists of three SPDT power relays, designated K601-K603, with coils operated via the RJ-25 control connector. The purpose of these relays is to transfer RF from one of the three networked SP-IIs (shown as STN1, STN2 and STN3) to the antenna. Note that the SSRU grounds the coax cable from non-selected SP-IIs. Each SP-II also grounds the antenna input to each unselected transceiver, thus providing a double margin of protection and a high degree of RF isolation.

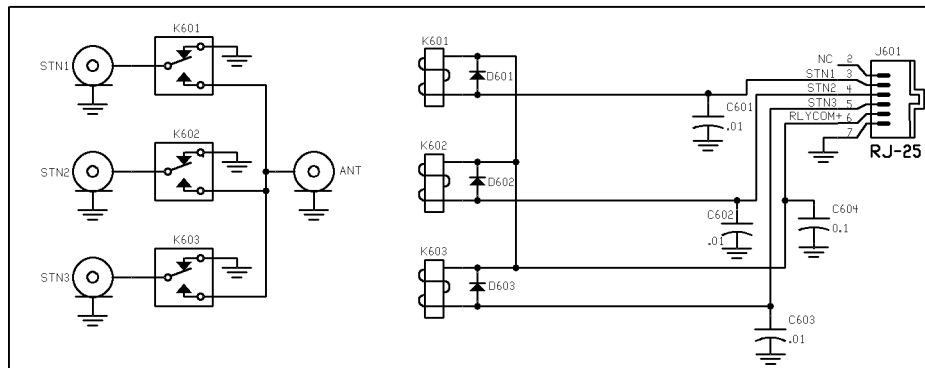

Network Logic and Firmware

The StationPro uses a simple but effective networking protocol to communicate among networked SP-IIs. There are two ports on the Basic Stamp BS-21C microcontroller in each SP-II, labeled REMOUT (port P10) and REMSNSE (port P9). REMSNSE is normally an input port which monitors the state of pin 2 of the “Rem In” and “Rem Out” RJ-25 jacks on each SP-II’s rear panel. The state of the REMSNSE line is normally high (+5V). However, when a transceiver or amplifier switch on any SP-II front panel is depressed, that SP-II puts a 100msec low pulse (0V) on the REMSNSE line. This pulse is detected by the other SP-IIs, and commands them to go off-line. Thus, the SP-II most recently operated is always on-line, and the others are always off-line. The on-line SP-II then commands its own REMOUT port to go low, which activates the appropriate relay in the SSRU.

III. Assembly Instructions for the Station Select Relay Unit

Preparation for Assembly: Collect together the following parts, required for assembling the SSRU:

Qty 1	PCB	4"W x 2.9"H Station Select printed circuit board (supplied free by W8ZR)
Qty 1	Enclosure	Hammond diecast enclosure 4.7"W x 3.7"H x 2.1"D Mouser p/n 546-1590CFBK (black, w/flange) Price: \$23.99
		<u>Alternate:</u> Hammond diecast enclosure 4.7"W x 3.7"W x 2.1"D Mouser p/n 546-1590CF (unpainted, w/flange) Price \$18.44
Qty 3	D601-D603	Fairchild 1N914A (or equivalent) gen purpose signal diode Mouser p/n 512-1N914 Price: \$0.03
Qty 4	coax jacks	UHF SO-239 AIM/Cambridge chassis mount jacks Mouser p/n 601-25-7350 Price \$1.33/ea
Qty 1	J601	RJ-25 jack, 6 pin, top entry, PCB mount Mouser p/n 806-GDX-PNS-66 (shielded) Price \$2.54
		<u>Alternates:</u> Mouser p/n 571-5520258-3 (unshielded) Price \$0.65
		Mouser p/n 571-5520425-3 (unshielded) Price \$0.75
Qty 3	K601-K603	Tyco/Schrack Relay RTB14012F SPDT 12A Mouser p/n 655-RTB14012F Price \$1.73/ea,
Qty 3	C601-C603	0.01 μ F capacitor 50V Xicon Z5U epoxy dipped ceramic Mouser p/n 21RZ410-RC Price: \$.08/ea
Qty 1	C604	0.1 μ F capacitor 50V Xicon Z5U epoxy dipped ceramic Mouser p/n 21RZ310-RC Price: \$.08/ea
Qty 3	hardware	threaded spacer, rnd aluminum (4-40) x 1/4" Mouser 534-2025 Price: \$0.34/ea

The following hardware items can be obtained locally (pan-head phillips stainless steel hardware preferred).

- Qty 6 4-40 x 3/16" machine screws (to secure PCB to enclosure)
- Qty 8 4-40 x 5/16" machine screws (to secure SO-239 coax jacks to RF relay enclosure)
- Qty 8 4-40 nuts
- Qty 14 No. 4 internal tooth lockwashers

Assembly Instructions (estimated assembly time is two hours):

(1) Cut out the provided template and secure it with tape or artist's dry-mount spray adhesive to the outside of the lid of the Hammond diecast enclosure. Be sure to center the template on the lid.

(2) Center punch all the holes on the template (15 total).

(3) Using a sharp knife or single-edged razor blade, carefully scribe guidelines that follow the rectangular cutout on the template.

(4) Drill or punch 5/8 in. holes at the four large hole locations in the top enclosure lid.

(5) Drill a series of 1/8" holes inside the rectangular cutout guidelines, to enable a small file to fit in the cutout.

(6) Using a small flat file, file out the rectangular cutout until the edges reach the scribed guidelines.

(7) Drill 1/8 in. holes at all the small hole locations in the top enclosure lid. If you prefer, you can use the SO-239 jacks as templates for the SO-239 mounting holes, as shown below.

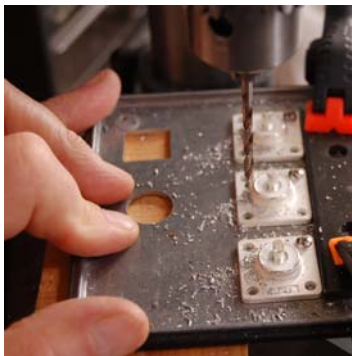

(8) Label the coax jacks STN1, STN2, STN3 and OUT, using the circuit board silkscreening as a guide to which jack is which.

(9) Mount all four SO-239 UHF coax jacks to the inside surface of the enclosure cover. Use two 4-40 x 5/16" machine screws, with internal lockwashers and nuts on each of the

SO-239 connectors. The lockwashers go under the nuts. There is a slight bit of wiggle room in the mounting holes, so use it to line up the connectors so their sides are parallel to one another.

(10) Mount three 4-40 x 1/4" threaded standoffs on the corner holes of the inside top cover. Use 4-40 x 3/16" machine screws, with internal lockwashers under the standoffs (i.e., between the standoffs and the enclosure, not under the screw heads.)

(11) Identify the Station Select Relay printed circuit board, shown below, and collect the components that mount on the board. (Note: the photo is of version A0 of the board. Version A1 has only three mounting holes.)

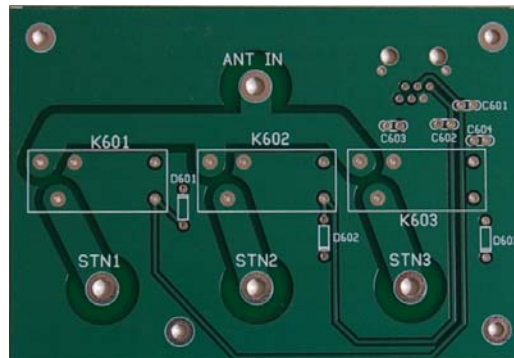

Station Select Relay Circuit Board (Top View)

(12) Plug J601, the 6-pin RJ-25 connector, into its holes on the *rear side* of the circuit board, but do not solder the pins yet.

(13) Temporarily mount the Station Select Relay circuit board onto the inside of the top cover, making sure the center pin of each SO-239 jack extends into its mating hole on the circuit board, and that the body of J601 fits through the rectangular cutout on the cover. Loosely secure the circuit board to the three standoffs with 4-40 x 3/16" screws in order to verify that the holes line up. Once you're sure everything fits together properly, solder the pins on J601. Do not solder the pins yet on the coax jacks. Now unscrew the three 4-40 x 3/16" screws that you just installed, and remove the circuit board from the enclosure.

(14) In the following steps, all components mount on the top of the circuit board. Install 0.01 $\mu\text{F}/50\text{V}$ (marked 103) epoxy coated ceramic capacitors at C601-C603.

(15) Install a 0.1 $\mu\text{F}/50\text{V}$ (marked 104) epoxy coated ceramic capacitor at C604.

(16) Install 1N914A diodes at D601-D604, taking care to observe the diode polarity. The banded end of the diodes is indicated on the silkscreened legend.

(17) Install RF power relays K601– K604. Install these one at a time and make sure the body of each relay is flush against the circuit board before you solder the pins.

(18) Secure the RF circuit board to the three standoffs on the inside top cover of the enclosure, using 4-40 x 3/16" machine screws and internal lockwashers. Place the lockwashers between the standoffs and the bottom of the circuit board (NOT under the screw heads). (*Hint: balance the lockwashers on top of the standoffs and carefully lower the circuit board with the screws dangling in each corner onto the standoffs.*)

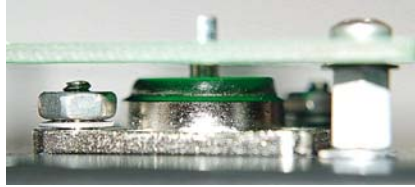

Lockwashers go between the standoffs and the circuit board and enclosure lid, not under the screwheads. The lockwashers ensure good electrical contact between the circuit board ground plane and the enclosure lid, and also increase the clearance between the bottom of the circuit board and the SO-239 connector bodies. Note that the lockwashers on the SO-239 jacks go under the nuts.

(19) Make sure all the hardware securing the four SO-239 jacks is tight, and then solder all four center pins of the SO-239 connectors to the circuit board pads. Use enough heat to make certain the solder flows nicely, but use no more solder than necessary for a good connection.

(20) Attach the cover to the Station Select relay enclosure using the screws provided with the enclosure. This completes the assembly of the Station Select Relay Unit.